

DHI-ISC-M1001000

Intelligent Security Screening Machine



The intelligent security screening machine adopts dual energy detector that uses X-ray to quickly inspect baggage and goods without opening packages.

System Overview

The machine adopts an advanced X-ray image detection system, which integrates semiconductor detectors, digital image processing technology and computer image display technology, to provide users with an efficient, reliable and high-quality image processing system that has service functions. The device has a large HDD capacity that can store massive high-definition images. It supports many functions. It recognizes prohibited objects, alarms when prohibited objects are detected and features person-package linkage, image enhancement, network expansion and interconnection, automatic detection and maintenance and more. In addition, the operation design is simple and user-friendly.

Functions

X-ray Package Image Generating

Adopts the Dahua algorithm to generate images of packages and their content, displaying their shape and the materials that they are made of. The generated images reflect X-ray absorption degrees and material composition. To better identify dangerous items, scanned objects will be categorized into organic matter, mixture and inorganic matter, and marked in orange, green and blue respectively according to their composition.

X-ray Package Image Enhancement

Adopts Dahua algorithm and enhances package images with different effects so that operators can better analyze the items. Enhancement functions include color/black and white, local enhancement, super enhancement, edge enhancement, image scanning, organic stripping, metal stripping, Inverse, high-energy enhancement, low-energy enhancement, light, dark, density threat alert Z7/Z8/Z9, high density alert, AI overlay, vertical flip, pseudo color and more.

Dual-screen Display Video Output

Displays images in security mode (package images) or video surveillance mode.

- Uses X-ray to generate images of packaged items passing on the conveyor belt, and checks the shape and size of packaged items.
- Displays images of the packages with enhanced effects, such as high energy enhancement, super enhancement, high density alert and image scanning.
- Supports security screening mode and video surveillance mode.
- Generates dual view images simultaneously, generates penetration images of contraband at different angles.
- Recognizes dangerous items such as knives, bottled liquid, spray cans, guns and lighters from scanned images.
- Set danger levels for suspect items and link alarms such as voice prompt, sound and light alarm and conveyor belt stopping.
- Displays AI overlay on suspected objects. The AI overlay box moves with the package.
- All detection results can be stored and generated as reports, which can be searched and exported according to danger level and time.
- 2 built-in cameras that respectively monitor the entry and exit of baggage and the package inspection process.
- Add IP camera and PoE camera for live video, storage and playback. The cameras monitor the entire security inspection.
- Supports HDD storage space management and advanced management such as RAID configuration (RAID0/1/5).
- Supports system operation and maintenance management, such as self diagnosis, log and online user search, and device updating.
- Dust, moth, and mold protection for key components.
- Enhanced reliability through submodule isolation design.

Dangerous Items Recognition

Adopts the Dahua algorithm to analyze X-ray images of packages and identify dangerous items such as knives, bottled liquid, pressure tanks, guns and lighters. It also tracks dangerous items by using AI overlay which can be marked in different colors to indicate danger levels. Alarm linkage are supported such as voice prompt, sound and light alarm and conveyor belt stopping.

Package Linkage

Included are the entrance camera and exit camera. The system supports real-time recording, and offers person-package linkage storage and search.

Package Statistics

All detection results can be stored and generated as reports, which can be searched and exported according to danger level and time.

Continuous Scanning

Continuously scans packages and displays their images even when the system restarts after being stopped.

Safety Protection

X-ray protection is higher than the international standard. The leakage dose is less than 0.9 µGy/h.

Scene

The machine is used for security screening of handbag, briefcase, postal parcels, express parcels, cargo and other big luggages. It is applicable for use in government buildings, courts, procuratorates, public security and more.

Technical Specification

System

CPU	Intel quad-core processor
RAM	16 G
Operating System	Embedded Linux OS
User Interface	Local GUI (full functions); Web interface

Basic

Tunnels Size	1000 mm × 1000 mm (39.37" × 39.37")
X-ray Generator	Single-View
X-ray Tube Anode Voltage	160 kV
X-ray Tube Cooling	Sealed oil bath with forced air
Wire Resolution	Typical: 36AWG(0.127mm); standard: 34AWG(0.16mm) *
Penetration(steel)	Typical: 38 mm; standard: 36 mm *
Leakage Dose-rate	≤ 0.9 µSv/h (µGy/h)
Noise Level	≤ 63 dB
Conveyor Speed	0.2 m/s
Conveyor Height	290 mm - 370 mm adjustable
Maximum Belt Load	200kg (440.92 lb)
Current Leakage	≤ 0.25 mA
Film Safety	ISO 1600 (33 DIN)

Intelligent Analysis

Preview	Real-time display of X-ray package image and camera image; real-time item intelligent analysis
Item Recognition	Recognizes items and displays AI overlay; the AI overlay box moves with packages
Recognition Types	Recognizes 23 types of objects: Guns, fireworks, spray cans, knives, axes, scissors, lighter fluid, nail polish, bottled liquids, glass bottles, thermos bottles, plastic bottles, handcuffs, nightsticks, brass knuckles, lighters, tools, electronic products, mobile phones, powerbanks, laptops, umbrellas and high density object
Danger Levels	High risk, warning, and safe (supports custom configuration according to types of objects)
Event Linkage	I/O alarm, voice prompt, platform alarm and screen notification can be triggered according to danger levels
Image Storage	Stores as much as 1 million images with information on their danger levels and the types of objects detected. Original and analyzed images can both be viewed.

*Measured by Dahua Imaging Test Kit

Baggage Search	Search, play back, and export baggage images and linked videos according to time, objects type and more
Report Search	Generate and export reports according to time and object types
Backup	USB/Network

Performance

Self-inspection	Automatically detects system failures and prompts error codes
Image Processing	Enhancement functions include color/black and white, local enhancement, super enhancement, edge enhancement, image scanning, organic stripping, metal stripping, mixture stripping, inverse, high-energy enhancement, low-energy enhancement, light, dark, density threat alert Z7/Z8/Z9, high density alert, AI overlay, vertical flip, pseudo color and more
Image Playback	Supports playback of 30 images
Image Zooming	Zoom in X-ray images up to 64x, image smooth zooming. Drag the focus position using a mouse or direction- keys
Device Diagnosis	Supports diagnosis of key components such as the detector, motor, IR sensor and special keyboard
Detection Configuration	Key function configuration; image display configuration (vertical flip and max zoom times), scan mode configuration (double direction, forward scan, reverse scan, compulsory scan and power saving mode), baggage counter configuration and person-package linkage configuration

Basic

Graphics Output	2-channel DVI outputs; resolution: Up to 1920 (H) × 1080 (V) @60 Hz
Monitor	2 × 21.5" monitor
Video Input (Network)	12-channel input (max 4K); 8-channel IPC + 4 PoE (2 PoE by default)
Video Output (Network)	Real-time Baggage Monitoring, Input cameras
Recording Mode	Offers manual recording and recording plan. Recording plan features continuous recording, alarm event linked recording and no recording
Built-in Disks	Supports up to 4 × 10 T SATA disks and configures 1 × 4 T disk by default
Storage Management	Single; RAID 0/1/5 (Enterprise-level disks are recommended); global hot standby
Ethernet Ports	1 RJ-45 10M/100M/1000M self-adaptive Ethernet port; 4 RJ-45 PoE 10M/100M Ethernet ports
Internet Protocols	HTTP, HTTPS, TCP/IP, UDP, RTSP, IPv4, NTP, DHCP, DNS, IP Filter, IP Search (Support Dahua IP camera, DVR and more)
Interoperability	ONVIF, SDK and more
Biometrics	User Fingerprint Login (Optional)

Ports

232 Port	1-channel RS 232 port for controlling the operating keyboard
Power Port	2-channel port for monitor power supply
USB Port	2-channel USB3.0, 2-channel USB2.0
Display Port	2-channel DVI outputs
Emergency Stop Button	5 (4 buttons on the machine body and 1 button on the operating keyboard)

Power Button	1 (on the operating keyboard)
Key Switch	1 (on the operating keyboard)
Indicator Light	<p>On the machine: Power indicator: Turns solid green when the machine is working and flashes during updates and when an error occurs X-ray indicators: Turn solid red when X-ray is triggered and turns off when X-ray is turned off</p> <p>On the operating keyboard: Key switch indicator: Turns solid green when the switch is turned on and turns off when the switch is turned off Power button indicator: Turns solid green when the power button on the operating keyboard is pressed on. Light turns off when the machine is powered off Press button indicators: Flashes green when one button is pressed on X-ray indicator: the red light is always on when X-ray is turned on, but not when X-ray is turned off</p>

Regular

Power Supply	220VAC-15%~+10%, 50/60 Hz; 100-130 VAC, 50/60 Hz (optional)
Typical Power Consumption	0.85 kW
Maximum Power Consumption	1.5 kW
Intelligent Temperature Control	Detects the temperature of main board and HDD and automatically adjusts fan speed to make it work stably and quietly
Operating Temperature	0 °C to +45 °C (32 °F to +113 °F)
Operating Humidity	0%–95% (RH), non-condensing
Storage Temperature	-20 °C to +70 °C (-4 °F to +158 °F)
Storage Humidity	0%–95% (RH), non-condensing
Dimensions	3,599 mm x 1,300 mm x 1,780 mm (141.70"x51.20"x70.10")
Package Size	2,170mm x 1,720mm x 2,049 mm (85.43"x67.72"x80.67")
Net Weight	1100 kg (2425.08 lb)
Gross Weight	1300 kg (2866.01 lb)
Installation Mode	Ground mount
Control Console Package Size & Weight	1276 mm x 376 mm x 200 mm (50.24"x14.80"x7.87"), 38.5 kg (84.88 lb)

Ordering Information

Type	Model	Description
Intelligent Security Screening Machine	DHI-ISC-M100100	Intelligent Security Screening Machine
		21.5 inch LCD Monitor x 2
		Out Sliding table
Accessories	DHI-ISC-M100-EC10	0.5m Extend Roller table
	DHI-ISC-M100-EC15	1.0m Extend Roller table
	DHI-ASM101A	Fingerprint reader
Control Console	DHI-ISC-MCC01	Control Console
	DHI-ISC-2DCC	2 monitors Control Console, with lock

Installation

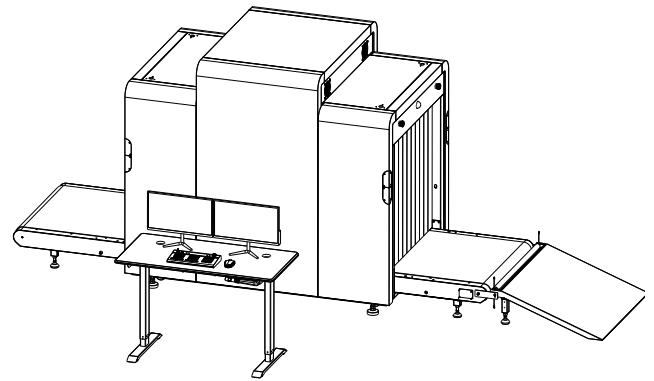

Dimensions (mm[inch])

